

SECTION B-B

PROPRIETARY AND CONFIDENTIAL
 THE INFORMATION CONTAINED IN THIS DRAWING IS THE SOLE PROPERTY OF SHAPEMASTER INC. ANY REPRODUCTION IN PART OR AS A WHOLE WITHOUT THE WRITTEN PERMISSION OF SHAPEMASTER INC. IS PROHIBITED.

| | | | |
|-------------|---------|---|--|
| | | DIMENSIONS ARE IN INCHES TOLERANCES: ANGULAR:MACH±. BEND ±. TWO PLACE DECIMAL ±.02 THREE PLACE DECIMAL ±.012 | |
| | | MATERIAL PTFE | |
| NEXT ASSY | USED ON | FINISH As Machined | |
| APPLICATION | | DO NOT SCALE DRAWING | |

| | | |
|------------|------|--------|
| | NAME | DATE |
| DRAWN | RL | 5.4.22 |
| ENG APPR. | | |
| MFG APPR. | | |
| Q.A. APPR. | | |
| Comments | | |

6 Slot - 4" Dipper V3



ShapeMaster Inc.
 P.O. Box 372
 108 E. Main Street
 Ogden, IL. 61859
 (886) 670-2799

| | | |
|-----------|-----------------|--------------|
| SIZE | PART NO. | REV. |
| A | SM4.6WD3 | |
| SCALE:1:2 | WEIGHT: | SHEET 1 OF 2 |

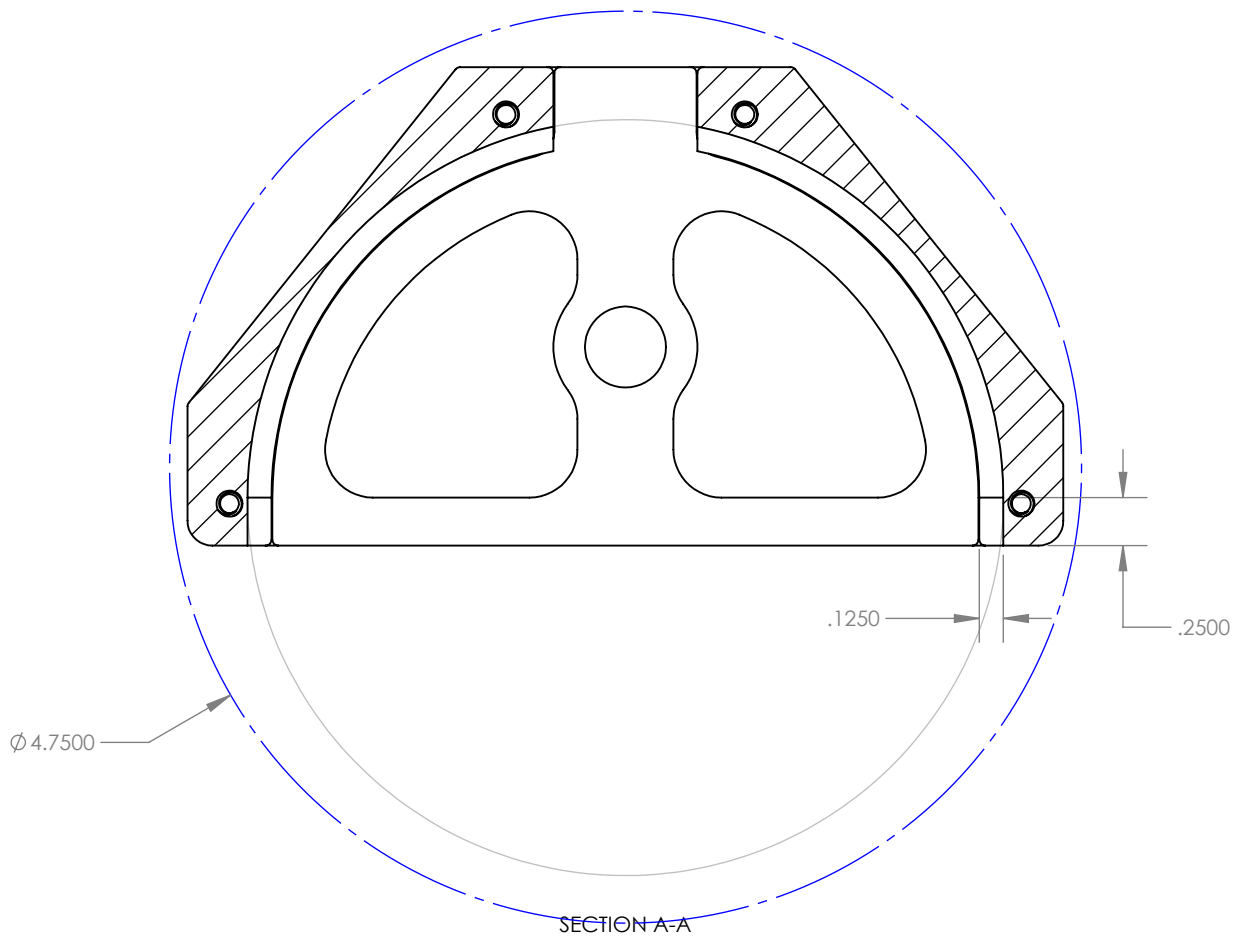
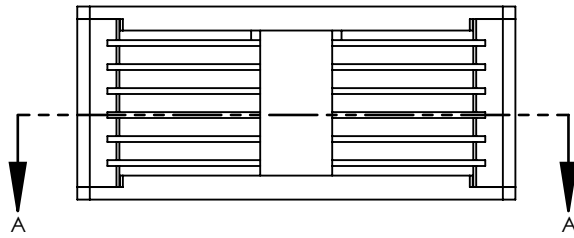

PROPRIETARY AND CONFIDENTIAL
 THE INFORMATION CONTAINED IN THIS DRAWING IS THE SOLE PROPERTY OF SHAPEMASTER INC. ANY REPRODUCTION IN PART OR AS A WHOLE WITHOUT THE WRITTEN PERMISSION OF SHAPEMASTER INC. IS PROHIBITED.

| | | | |
|-------------|---------|--|--|
| | | DIMENSIONS ARE IN INCHES TOLERANCES: ANGULAR:MACH±. BEND±. TWO PLACE DECIMAL ±.02 THREE PLACE DECIMAL ±.012 | |
| | | MATERIAL PTFE | |
| NEXT ASSY | USED ON | FINISH As Machined | |
| APPLICATION | | DO NOT SCALE DRAWING | |

| | | |
|------------|------|--------|
| | NAME | DATE |
| DRAWN | RL | 5.4.22 |
| ENG APPR. | | |
| MFG APPR. | | |
| Q.A. APPR. | | |
| Comments | | |

5 Slot - 4" Dipper V3



ShapeMaster Inc.
 P.O. Box 372
 108 E. Main Street
 Ogden, IL. 61859
 (886) 670-2799

| | | |
|------------|----------|--------------|
| SIZE | PART NO. | REV. |
| A | SM4.6WD3 | |
| SCALE: 1:1 | WEIGHT: | SHEET 2 OF 2 |