

SECTION A-A
SCALE 1 : 1

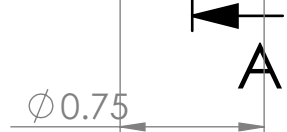

PROPRIETARY AND CONFIDENTIAL
THE INFORMATION CONTAINED IN THIS DRAWING IS THE SOLE PROPERTY OF SHAPEMASTER INC. ANY REPRODUCTION IN PART OR AS A WHOLE WITHOUT THE WRITTEN PERMISSION OF SHAPEMASTER INC. IS PROHIBITED.

		UNLESS OTHERWISE SPECIFIED:	NAME	DATE
		DIMENSIONS ARE IN INCHES	DRAWN	Ryan B 12/31/25
		TOLERANCES:	ENG APPR.	
		ANGULAR: MACH ± 1 Degree	MFG APPR.	
		BEND ± .	Q.A. APPR.	
		TWO PLACE DECIMAL ±.03	Comments:	
		THREE PLACE DECIMAL ±.		
		INTERPRET GEOMETRIC TOLERANCING PER:		
		MATERIAL		
		FINISH		
NEXT ASSY	USED ON			
APPLICATION		DO NOT SCALE DRAWING		

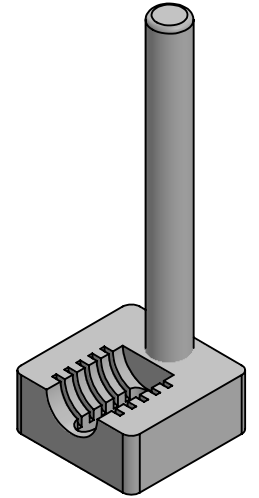
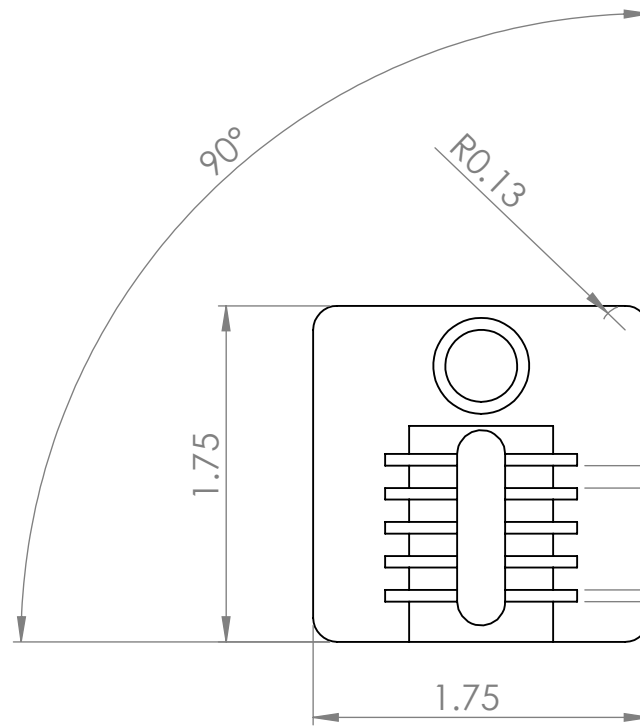

ShapeMaster Inc.
P.O. Box 372
108 E. Main Street
Ogden, IL. 61859
(800) 779-6925

SIZE	PART NO.	REV
A	1.5VWD1 REVB	
SCALE 1:1		SHEET 1 OF 1

5

4

3

2

1