

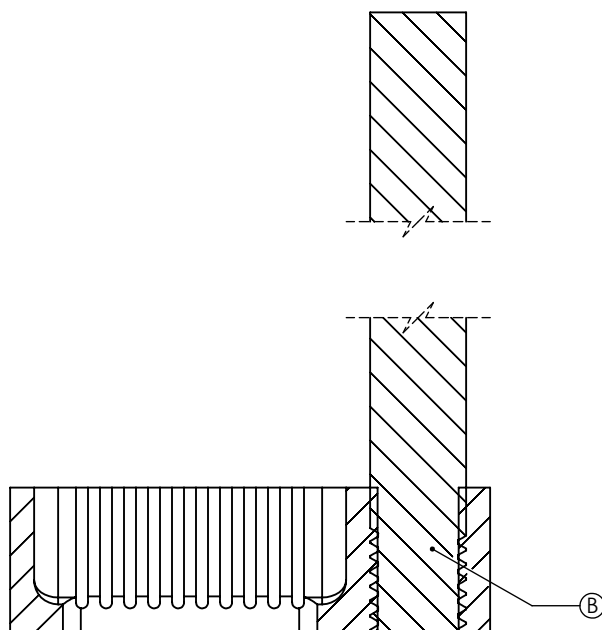

REVISIONS				
ZONE	REV.	DESCRIPTION	DATE	APPROVED
B1	B	Handle Updated to Threaded Design.	4/15/2022	RL

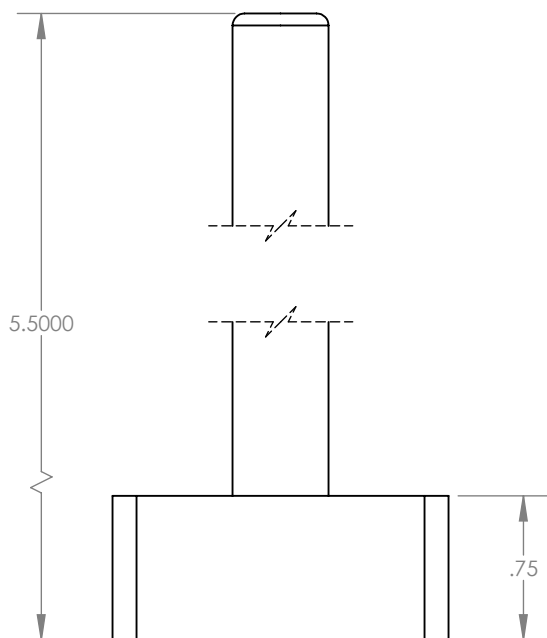
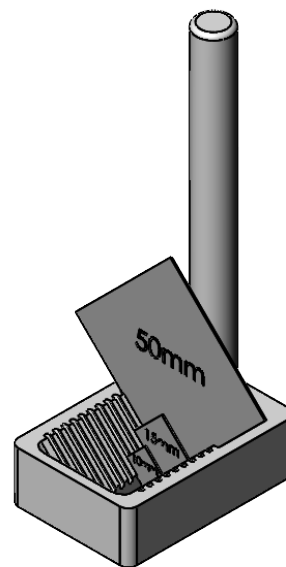
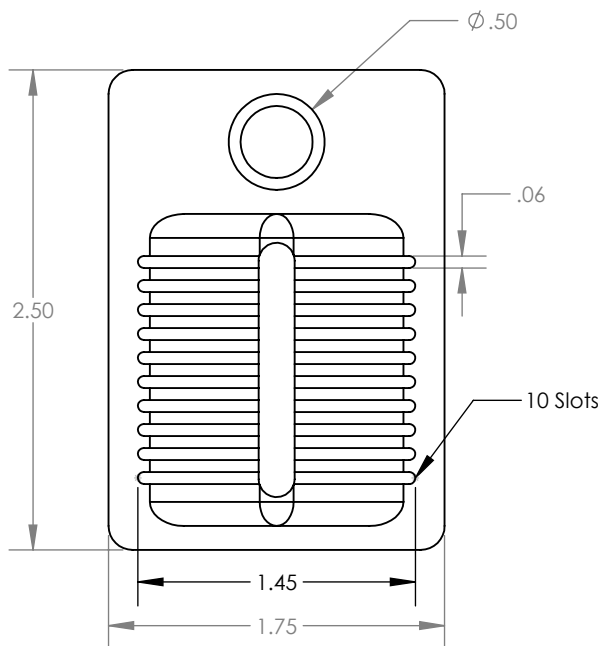

PROPRIETARY AND CONFIDENTIAL
 THE INFORMATION CONTAINED IN THIS DRAWING IS THE SOLE PROPERTY OF SHAPEMASTER INC. ANY REPRODUCTION IN PART OR AS A WHOLE WITHOUT THE WRITTEN PERMISSION OF SHAPEMASTER INC. IS PROHIBITED.

		DIMENSIONS ARE IN INCHES TOLERANCES: ANGULAR:MACH ±.01 BEND ±.01 TWO PLACE DECIMAL ±.01 THREE PLACE DECIMAL ±.005
		MATERIAL PTFE
NEXT ASSY	USED ON	FINISH
APPLICATION		DO NOT SCALE DRAWING

	NAME	DATE
DRAWN	RI	11/17
CHECKED		
ENG APPR.		
MFG APPR.		
Q.A.		
COMMENTS:		

Previous P/N	SM2.5WD7
 ShapeMaster Inc. P.O. Box 372 108 E. Main Street Ogden, IL. 61859 (886) 670-2799	
SM2.5WD1	
SIZE	DWG. NO.
A	
SCALE: 1:2	WEIGHT:
REV.	SHEET 1 OF 1
B	